

# ridetech



Air Ride Technologies

350 S. St. Charles St. Jasper, In. 47546

Ph. 812.482.2932 Fax 812.634.6632

[www.ridetech.com](http://www.ridetech.com)

## Part # 11169525 67-69 Camaro & 68-74 Nova TruTurn System without Spindles

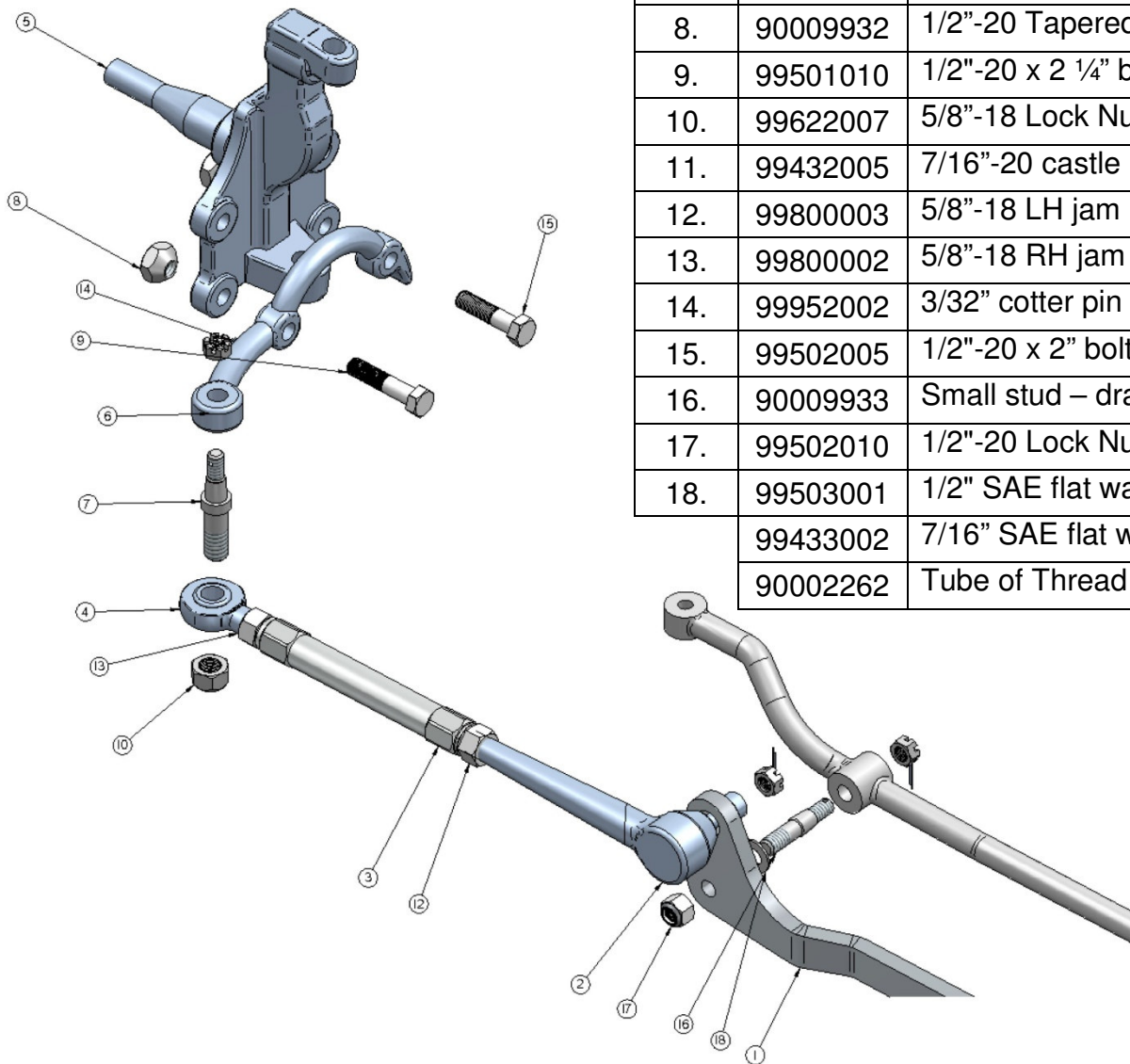

Item #	Part #	Description-Specification	Qty.
1.	90009930	Drag link bracket	1
2.	90003001	Driver inner tie rod	1
2.	90003002	Pass. Inner tie rod (bent)	1
3.	90007500	Adjusting sleeve	2
4.	90001590	Heim end	2
6.	90003000	Steering arm	1 pr.
7.	90009931	Large stud – tie rod	2
8.	90009932	1/2"-20 Tapered nut	4
9.	99501010	1/2"-20 x 2 1/4" bolt-75 ft lbs	2
10.	99622007	5/8"-18 Lock Nut-100 ft lbs	2
11.	99432005	7/16"-20 castle nut-35 ft lbs	6
12.	99800003	5/8"-18 LH jam nut	2
13.	99800002	5/8"-18 RH jam nut	2
14.	99952002	3/32" cotter pin	4
15.	99502005	1/2"-20 x 2" bolt-75 ft lbs	2
16.	90009933	Small stud – drag link	2
17.	99502010	1/2"-20 Lock Nut-75 ft lbs	2
18.	99503001	1/2" SAE flat washer	2
	99433002	7/16" SAE flat washer	6
	90002262	Tube of Thread Locker	1



Air Ride Technologies

350 S. St. Charles Street Jasper, In. 47546 [www.ridetech.com](http://www.ridetech.com)

## Installation instructions

1. Raise and safely support the front of your vehicle at a comfortable working level
2. Remove existing spindles and steering linkage, leaving only the control arms, steering box, and pitman arm in place.
3. Remove OEM inner tie rod ends from the OEM draglink as you will be re-using that original draglink.
4. Assemble the new RideTech draglink adapter bracket onto the OEM draglink with the supplied tapered studs and washers per the enclosed drawings.
5. Install the new RideTech spindles onto the control arms per the enclosed drawings. NOTE: The RideTech spindle has been fitted with the RideTech control arms. IF you are using another brand of control arms, or OEM control arm...MAKE SURE to run the suspension through its travel to ensure there is no ball joint bind and that proper alignment can be achieved. Torque balljoint nuts to 83 ft lbs.
6. Install the remainder of the Tru Turn steering linkage as shown in the attached drawings. MAKE SURE that ALL cotter pins are used in the appropriate places and that there is no binding or interference throughout the entire suspension travel.
7. Adjust the camber and toe roughly until you can get the vehicle to a proper alignment shop. The recommended alignment settings are:

Camber - -.5 to -1.5 [within .3 from side to side]

Caster - 4 to 7 degrees positive

Toe - 1/8 to 1/4 toe in

Feel free to experiment with alternative alignment settings that may be more appropriate for your particular driving style.

## Installation notes:

- A. The draglink bracket has one attachment hole [A] that is slotted. This is to accommodate the variations in manufacturing and machining processes from 1967, as well as any wear that may have occurred to the original draglink since that time.
- B. RideTech has successfully fitted a Baer disc brake system to this spindle. Other brands of disc brake brackets MAY need clearancing or adjustment for proper installation. The RideTech spindle duplicates the GM A body and F body bolt pattern [B] for brake bracket installation.
- C. MAKE SURE that the cotter pins are properly installed in all appropriate places [C] to ensure that the castle nuts do not become loose and fail. These are VERY important connections!
- D. IF your oem drag link is severely worn at the inner tie rod attachment holes [D] you may need to replace that unit with a new oem style draglink to ensure that the [RideTech supplied] tapered pin adapters DO NOT pull through that hole.

350 S. St. Charles St. Jasper, In. 47546  
 Ph. 812.482.2932 Fax 812.634.6632  
[www.ridetech.com](http://www.ridetech.com)

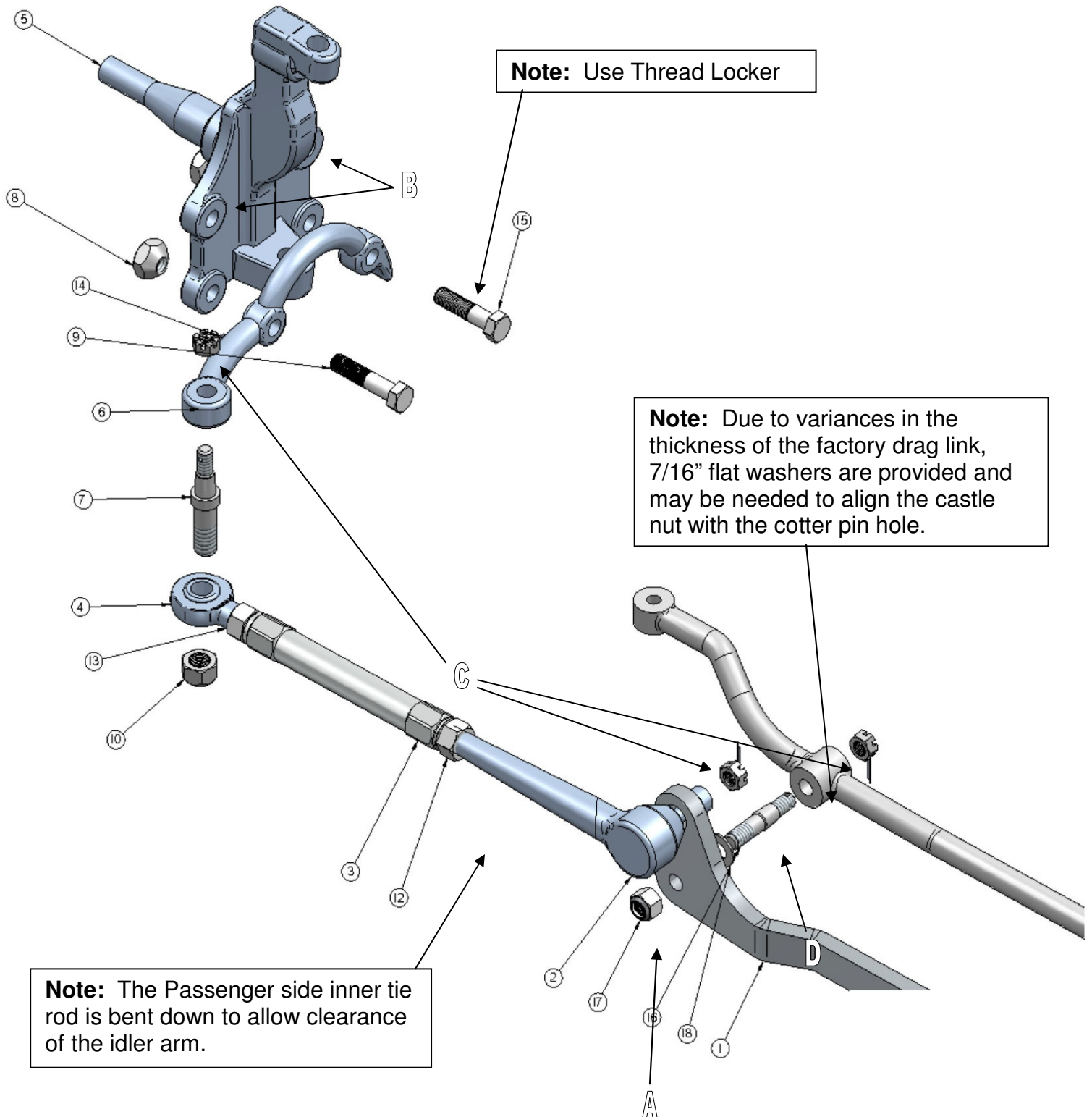

**Note:** Use Thread Locker

**Note:** Due to variances in the thickness of the factory drag link, 7/16" flat washers are provided and may be needed to align the castle nut with the cotter pin hole.

**Note:** The Passenger side inner tie rod is bent down to allow clearance of the idler arm.

350 S. St. Charles St. Jasper, In. 47546  
Ph. 812.482.2932 Fax 812.634.6632  
[www.ridetech.com](http://www.ridetech.com)



**Note:** If using a factory style stamped caliper bracket, the bracket may need to be trimmed. The dust shield may also need to be modified.

ridetech  
Air Ride Technologies