

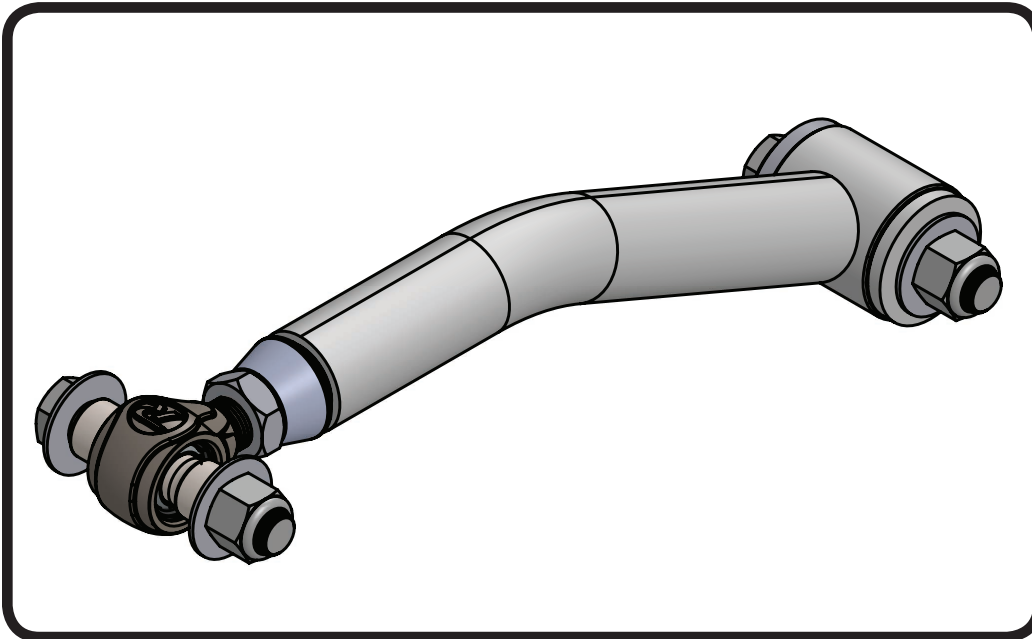

Part # 11066698 - 1959-1964 Full Size Chevy Rear Upper StrongArm Kit

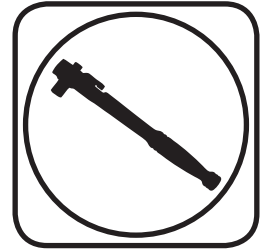

Recommended Tools



1959-1964 GM "B" Body Rear Upper StrongArms Installation Instructions

Table of contents

Page 2..... Included Components
Page 3..... Installation

Some vehicles have two factory upper arms and need a second tubular arm, Kit # 11066698.





Included ComponentsIn the box

Item #	Part #	Description	QTY
1	90001119	Upper Control Arm - set to 13.750"	1
2	90001318	R-Joint End	1
3	70013858	R-Joint Spacers	2
4	90001085	Poly Bushing Half - 1.5" Long	1
5	90001086	Poly Bushing Half - 1" Long	1
6	90000467	Inner Bushing Sleeve - 2.5" Long	1
7	99752004	3/4"-16 Jam Nut	1

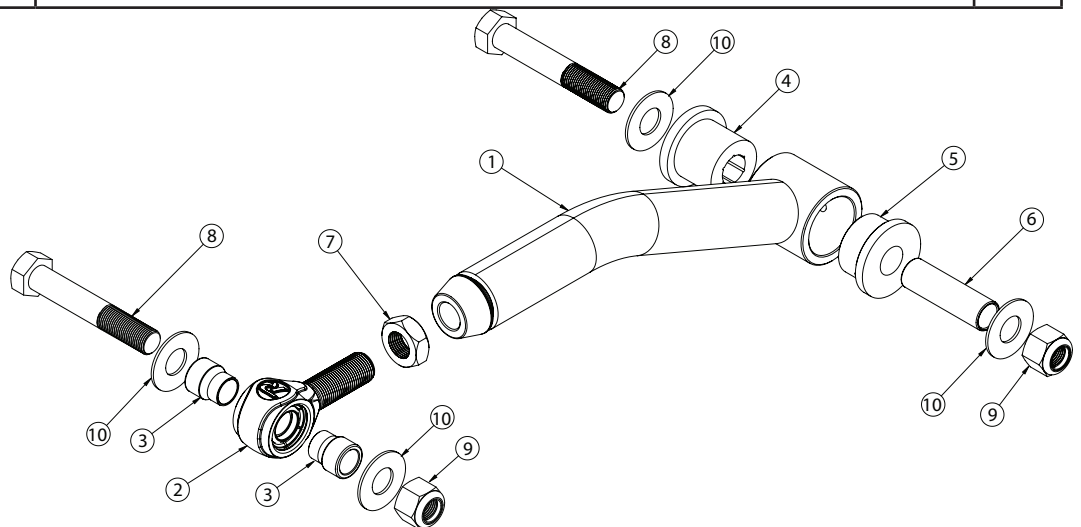

Hardware ListIn the box (Kit# 99010107)

Item #	QTY	Part Number	Description
8	2	99621006	5/8" -18 x 3 3/4" Bolt
9	2	99622006	5/8" -18 Nylok Nut
10	4	99623001	5/8" SAE Flat Washer

R-JOINT SPACER INSTALLATION

Install the Spacers by inserting the SMALL side of the SPACER into the Center Pivot Ball. Push them in until they bottom out and stop.

UPPER R-JOINTS

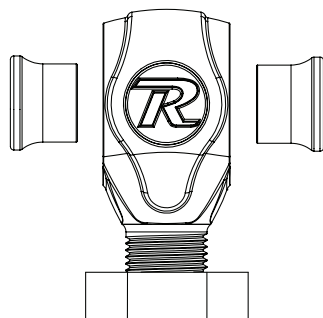

New R-Joints will be quite stiff (75-90 in/lbs breakaway torque) until they "break in" after a few miles of use. After the break in period they will move much more freely. Because the composite bearing race contains self lubricating ingredients, no additional lubrication is needed or desired. Any additional lubrication will only serve to attract more dirt and debris to the R-Joint and actually shorten its life.



Upper Bar Installation



1. Insert the Bushing end of the Upper Control Arm into the OEM mount. The control arm should be installed with the bend upward for better axle clearance. Install a 5/8" flat washer on a 5/8"-18 x 3 3/4" hex bolt through the mount and control arm bushing. Install a 5/8" flat washer, followed by a 5/8"-18 nylok jam nut onto the threads of the bolt. Tighten the hardware enough to eliminate any gaps.

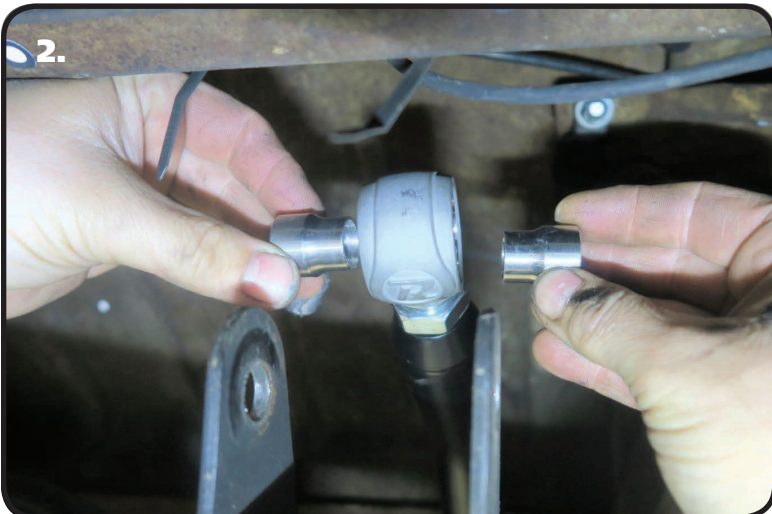

2. Insert the small diameter of the R-Joint Spacers into the center ball of the R-Joint. Insert the R-Joint/Spacers into the OEM mount of the differential.

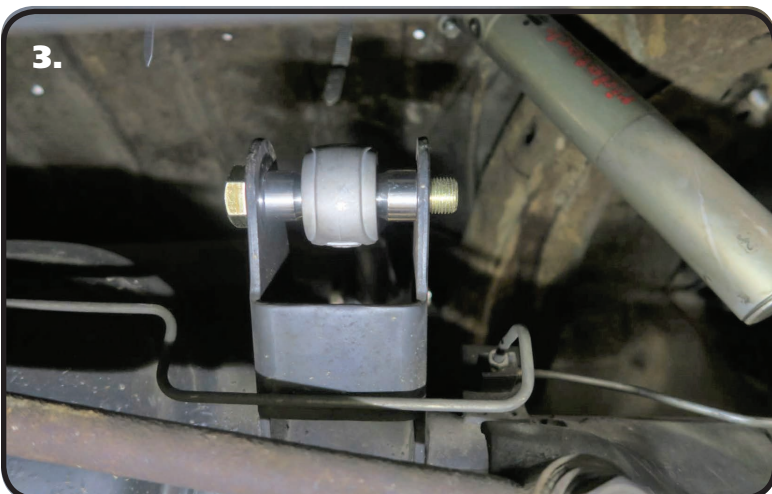

3. Install a 5/8" flat washer on a 5/8"-18 x 3 3/4" hex bolt through the mount and control arm R-Joint. Install a 5/8" flat washer, followed by a 5/8"-18 nylok jam nut onto the threads of the bolt. Tighten the hardware enough to eliminate any gaps.