



350 S. St. Charles St. Jasper, In. 47546
Ph. 812.482.2932 Fax 812.634.6632

www.ridetech.com

Part # 13042401

Mopar LX Platform Front Shockwave – HQ Series
05-08 Magnum / 05-Up 300C / 06-Up Charger / 08-Up Challenger

Shockwave:

2	24190198	1000 Master Series double convoluted bellow assembly
2	24559999	5" stroke shock w/ threaded bottom – HQ Series
2	90002357	Aluminum Reducer Puck
2	90009988	2" Stud top (Stud top base not needed)
2	90001668	(SKW076) Aluminum lower shock mount
2	90009980	(A953) Lower Shockwave steel bracket
2	234-00-153	Locking Ring

Components:

4	90002229	Steel washer for rubber mount (2.375" O.D.)
2	90001974	Upper rubber isolator
2	90001973	Lower rubber isolator (T-shaped)
2	90001971	Aluminum upper ShockWave plate
2	90002448	Wide Lower Shockwave steel bracket
2	31954201	1/4" x 1/4" swivel elbows

Hardware:

2	99562003	9/16" SAE Nylok jam nut	Stud top to upper mount
2	99561006	9/16" x 3 1/2" SAE bolt	Lower bracket to lower arm
2	99562005	9/16" SAE Nylok nut	Lower bracket to lower arm
6	99371006	3/8" x 1 1/2" USS bolt	Aluminum plate to body
6	99372001	3/8" USS Nylok nut	Aluminum plate to body
12	99373003	3/8" SAE washer	Aluminum plate to body
2	99501029	1/2"-13 x 6 1/2" Bolt	Lower Shock Mount to Shock
2	99503002	1/2" Split Lock Washer	Lower Shock Mount to Shock

Mopar LX Front ShockWave Assembly

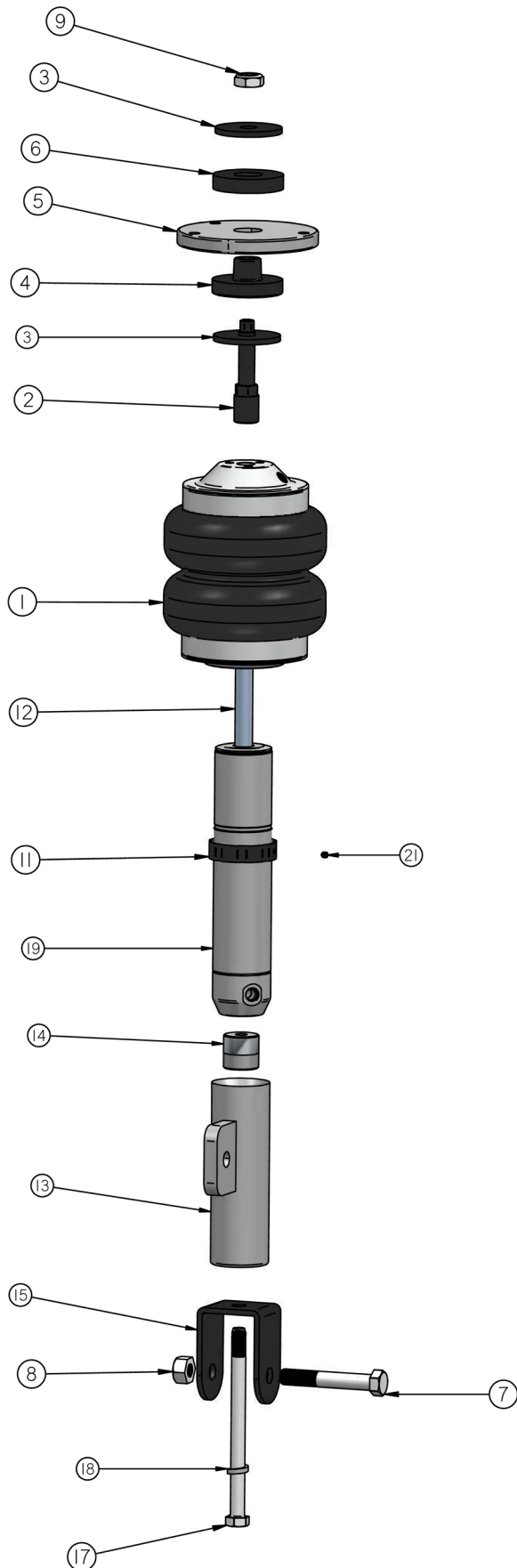

Item Number	Description	Qty.
1	255 (6.5") bellow assembly 24190198	2
2	Short stud top 90009988	2
3	Washer for Rubber Mount 90002229	4
4	Lower Rubber Isolator(T- shaped)90001973	2
5	Upper mounting plate 90001971	2
6	Upper Rubber Isolator 90001974	2
7	9/16" X 3 1/2" Bolt	2
8	9/16" SAE Nylok nut	2
9	9/16" SAE jam Nylok nut	2
11	Locking Ring 234-00-153	2
13	Bottom lower billet mount 90001668	2
14	Aluminum Reducer Puck 90002357	2
15	Lower Steel Shockwave Bracket-90009980	2
17	1/2"-13 x 6 1/2" USS bolt	2
18	1/2" Lock Washer	2
19	5.2" Shock w/ universal bottom - 24559999	2
21	Set Screw	2

SHOCKwave®

Installation Instructions

1. Raise the vehicle to a safe and comfortable working height with the suspension hanging freely.
2. Remove the factory struts and upper mounts; refer to the service manual for proper disassembly procedures.
3. Due to 2 possible lower mount options on this platform, included in the kit are 2 different widths of lower mounts.
4. Determine the width of Lower Mount required for your application by test fitting the supplied mounts. Refer to the diagram below for assembly and clocking of the lower bracket.

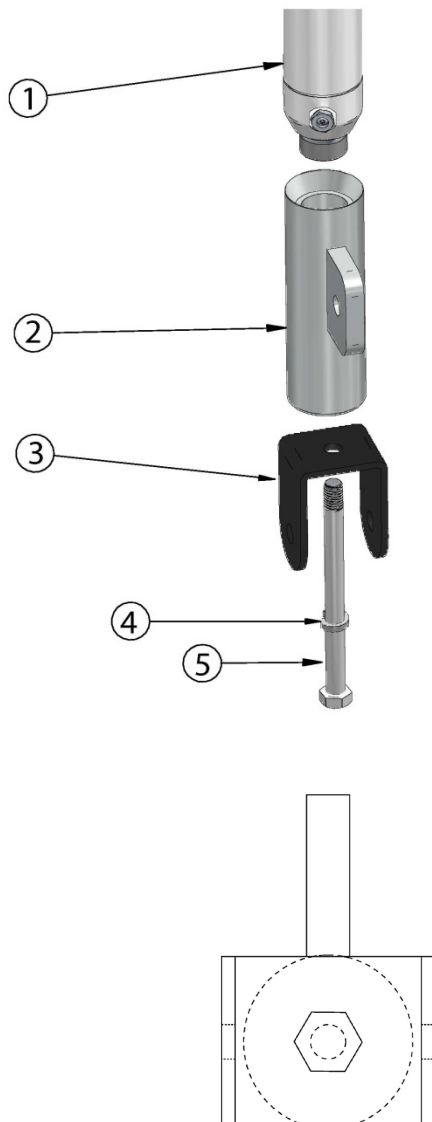

1. Shock Assembly
2. Lower Shock Adapter
3. Lower Shock Mount
4. 1/2" Split Lock washer
5. 1/2" x 6 1/2" Hex Bolt

Assembly

1. Slide the Shock Adapter onto the Shock Assembly.
2. Install the Split Lock washer onto the 1/2" x 6 1/2" Bolt.
3. Apply Red Loctite onto the threads of the bolt.
4. Insert the Bolt through the Lower Shock Mount and into the bottom hole of the Shock Adapter.
5. Thread the bolt into the Shock. **The Lower Shock Mount has to be clocked so that the Shock Mount Tabs run parallel with the Sway Bar Mount on the Adapter.** The diagram here shows correct clocking of the bracket.
6. With the bracket clocked correctly, tighten the 1/2" Bolt.

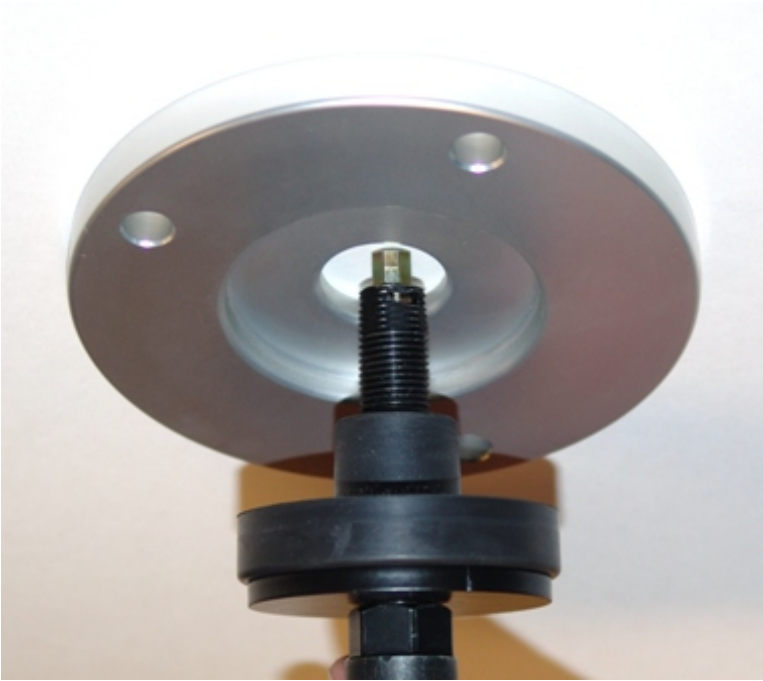

5. Bolt the aluminum upper plate to the car in place of the factory rubber mount using the 3/8" x 1 1/4" bolts, flat washer and Nylok nuts.

Note: The recessed side of the plate must face down.

6. Place one of the 2.375" steel washers over the threaded stud. Then slide the T shaped rubber bushing over the stud. Place the Shockwave into the coil spring pocket with the stud protruding through the hole in the aluminum plate.



7. From the engine bay, place the other rubber bushing over the stud, then another steel plate. Secure the assembly with a 9/16" SAE Nylok Jam nut. **Note:** Some cars may have a plastic cover in the engine bay that may need to be clearance for the adjustment knob.

8. Bolt the bottom of the Shockwave assembly to the lower arm using a 9/16" x 3 1/2" bolt and Nylok nut.

9. Attach sway bar to Shockwave using the factory hardware.



10. Apply thread sealant to an elbow air fitting and screw it into the top of the Shockwave.

11. Route the airline. Allow slack for suspension movement.

12. Check air spring clearance through full suspension travel. **Allowing the Shockwave to rub on anything will result in air spring failure and in not a warrantable situation.**

13. Ride height on this car is approximately 2" lower than factory. On most vehicle this will occur around 100psi, but will vary per vehicle.

The care and feeding of your new ShockWaves

1. Although the ShockWave has an internal bumpstop, **DO NOT DRIVE THE VEHICLE DEFLATED RESTING ON THIS BUMPSTOP. DAMAGE WILL RESULT.** The internal bumpstop will be damaged, the shock bushings will be damaged, and the vehicle shock mounting points may be damaged to the point of failure. **This is a non warrantable situation.**
2. Do not drive the vehicle overinflated or "topped out". Over a period of time the shock valving will be damaged, possibly to the point of failure. **This is a non warrantable situation!** If you need to raise your vehicle higher than the ShockWave allows, you will need a longer unit.
3. The ShockWave is designed to give a great ride quality and to raise and lower the vehicle. **IT IS NOT MADE TO HOP OR JUMP!** If you want to hop or jump, hydraulics are a better choice. This abuse will result in bent piston rods, broken shock mounts, and destroyed bushings. **This is a non warrantable situation.**
4. Do not let the ShockWave bellows rub on anything. Failure will result. **This is a non warrantable situation.**
5. The ShockWave product has been field tested on numerous vehicles as well as subjected to many different stress tests to ensure that there are no leakage or durability problems. Failures have been nearly nonexistent unless abused as described above. If the Shockwave units are installed properly and are not abused, they will last many, many years. **ShockWave units that are returned with broken mounts, bent piston rods, destroyed bumpstops or bushings, or abrasions on the bellows will not be warrantied.**

Shock adjustment 101- Single Adjustable

Rebound Adjustment:

How to adjust your new shocks.

The rebound adjustment knob is located on the top of the shock absorber protruding from the eyelet.

You must first begin at the ZERO setting, then set the shock to a soft setting of 20.



-Begin with the shocks adjusted to the ZERO rebound position (full stiff). Do this by rotating the rebound adjuster knob clockwise until it stops.



-Now turn the rebound adjuster knob counter clock wise 20 clicks. This sets the shock at 20. (settings 21-24 are typically too soft for street use).

Take the vehicle for a test drive.



-if you are satisfied with the ride quality, do not do anything, you are set!



-if the ride quality is too soft increase the damping effect by rotating the rebound knob clock wise 3 clicks.

Take the vehicle for another test drive.



-if the vehicle is too soft increase the damping effect by rotating the rebound knob clock wise 3 additional clicks.



-If the vehicle is too stiff rotate the rebound adjustment knob counter clock wise 2 clicks and you are set!

Take the vehicle for another test drive and repeat the above steps until the ride quality is satisfactory.

Note:

One end of the vehicle will likely reach the desired setting before the other end. If this happens stop adjusting the satisfied end and keep adjusting the unsatisfied end until the overall ride quality is satisfactory.