

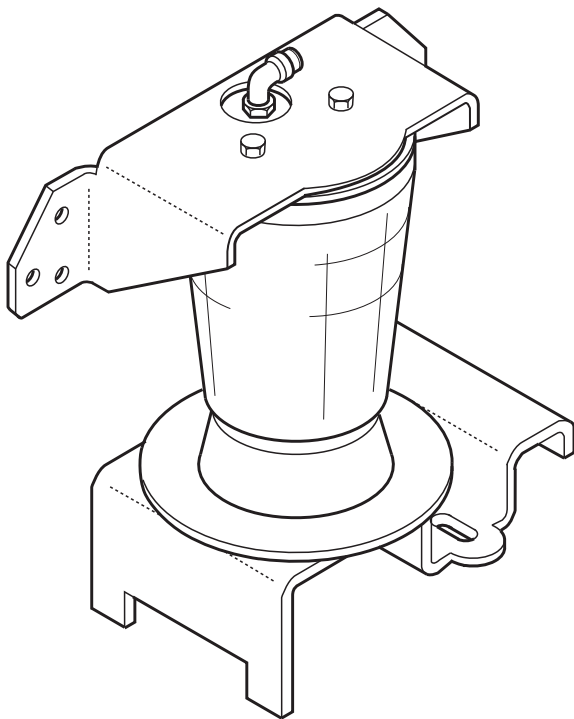

## 81223002 97-03 F150/F250 Non-SD 4WD

Congratulations - your new TowPro Helper Springs are quality products capable of improving the handling and comfort of your vehicle. As with all products, proper installation is the key to obtaining all of the benefits your kit is capable of delivering. Please take a few minutes to read through the instructions to identify the components and learn where and how they are used. It is a good idea to start by comparing the parts in your kit with the parts list below.



### Components

AIR SPRINGS	9000	2
UPPER BRACKETS	5377	2
LOWER BRACKETS	5505	2
3/8" NUT PLATES	5245	4
DISK	5260	2
BRACKET STRAPS	5086	2
BRAKE LINE BRACKET(Ford)	5375	1

### Hardware

3/8"-16 X 1-1/2" HEX BOLTS	8
3/8"-16 FLANGE LOCK NUTS	8
3/8"-16 X 3/4" HEX BOLTS	6
3/8" SPECIAL FLAT WASHERS	8
3/8"-16 X 3.62" X 3" BAIL CLAMP	4
5/16" FLAT WASHERS	4
NYLON TIES	6
THERMAL SLEEVES	2

#### WARNING!

Do not inflate this assembly when it is unrestricted. The assembly must be restricted by the suspension or other adequate structure. Do not inflate beyond 100 P.S.I. Improper use or over inflation may cause property damage or severe personal injury.

**FIGURE "A"**

**NOTE:** Both illustrations are of the left side of the vehicle. Reverse any orientations when assembling and installing the right side of the vehicle. Both airsprings are located just ahead of the vehicle's axle.

**KIT TO FRAME ASSEMBLY**

**NOTE:** FORD vehicles ONLY use supplied brake line bracket to relocate brake line.

GM vehicle frame rails may have reinforcing ribs on the frame rail. DO NOT drill through these ribs, simply allow the upper bracket flange to rest on the rib (refer to step 5).

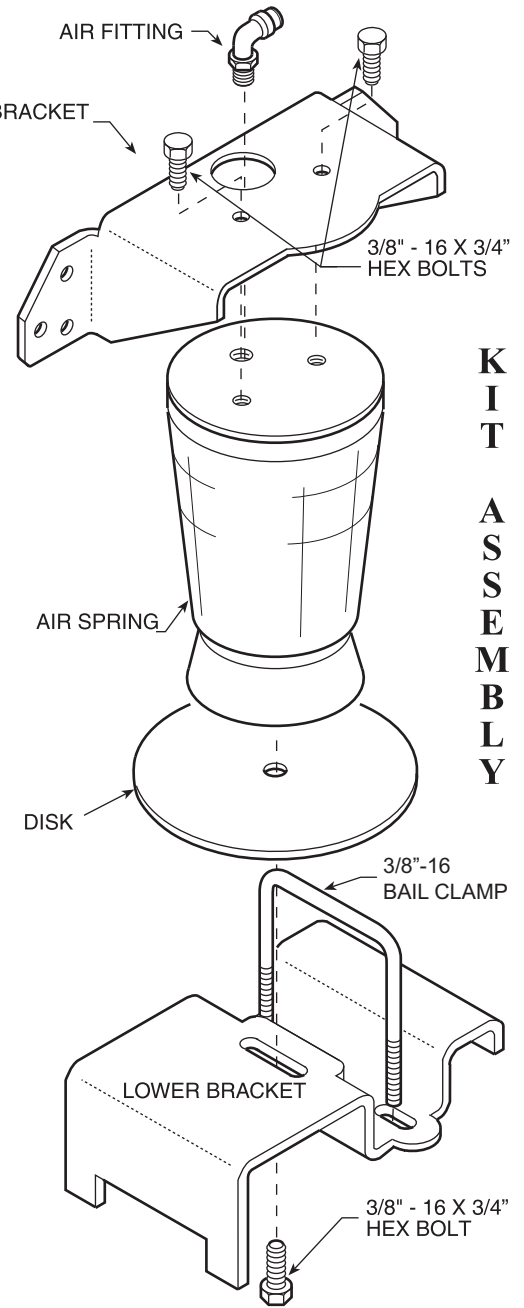
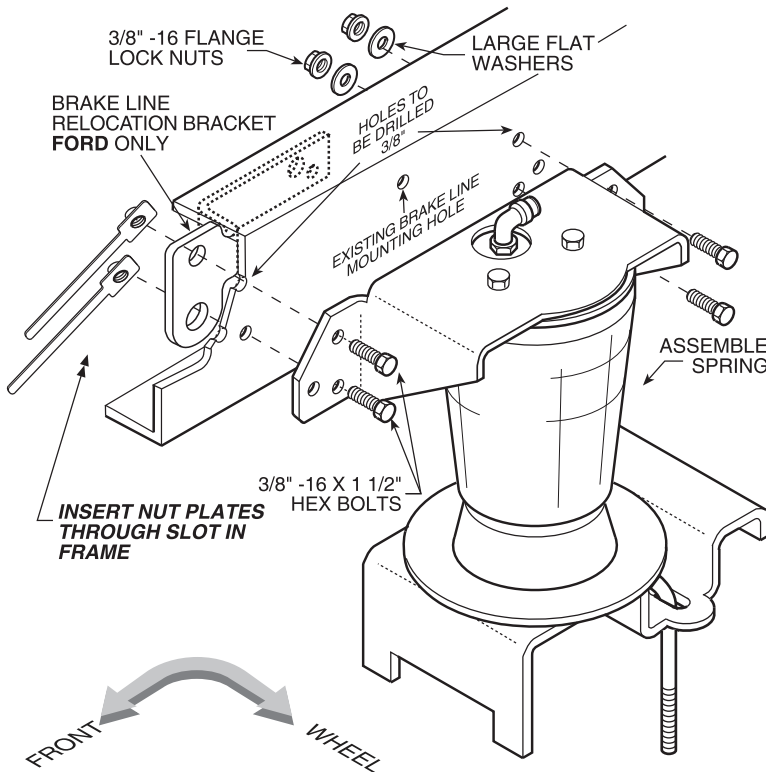

**K  
I  
T  
A  
S  
S  
E  
M  
B  
L  
Y**

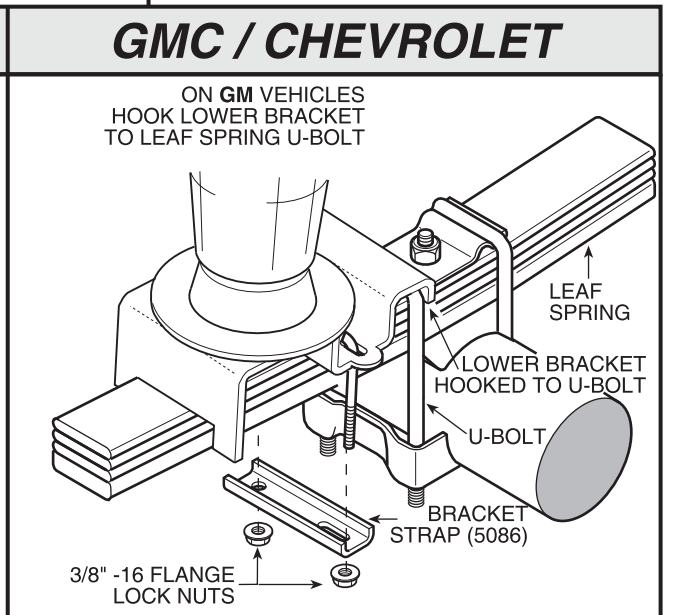
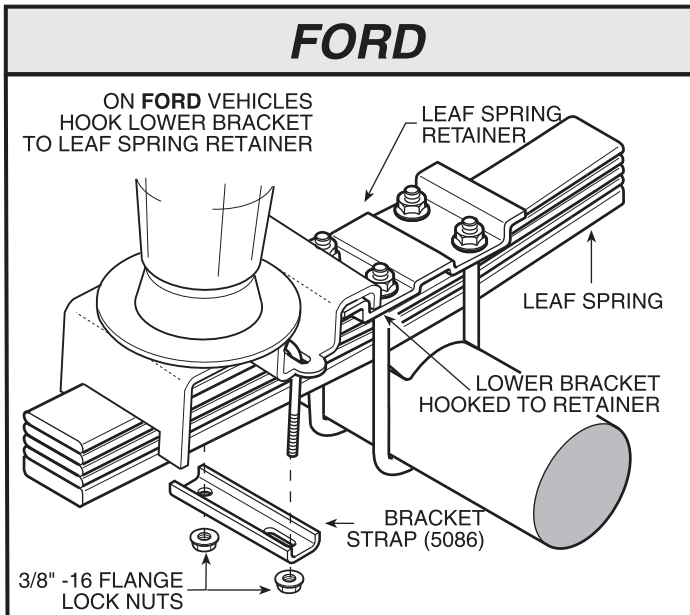

## STEP 1 - PREPARE THE VEHICLE

First, measure the distance between the tire and frame. If there is less than 6" of clearance, **do not proceed**. There should be no extra weight in the bed of the truck so that the initial ride height of your air helper spring kit will be correct. With the vehicle on a solid, level surface chock the front wheels. Raise the vehicle by the axle and remove the rear wheels. After the removal of the wheels, lower the vehicle so the axle rests on jack stands rated for your vehicles weight. Remove the negative battery cable.

### THE "X" DIMENSION.

Throughout this manual we refer to an "X" dimension. This is the initial, un-inflated overall height of the air spring. Both right and left sides should be installed at the same height. The "X" dimension on this air spring is 7" to 9". The air spring may require some stretching to achieve this dimension.

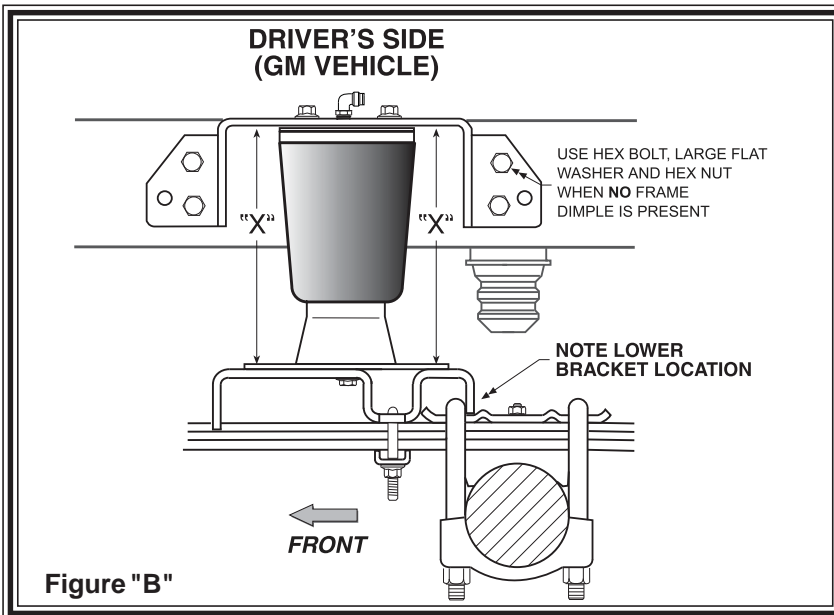

Figure "B"

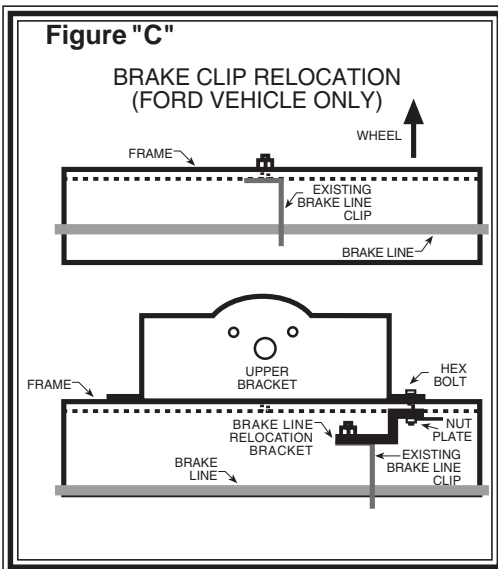

Figure "C"

9". The air spring may require some stretching to achieve this dimension.

## STEP 2 - PRE-ASSEMBLE THE KIT

Select one air helper spring from your kit. Install the upper bracket by aligning the three holes on the air spring with the holes on the upper bracket. Fasten the upper bracket to the air spring using the 3/8" x 3/4" hex bolts as shown in *Figure "A"*. Install the air fitting as shown in *Figure "A"*. Tighten the air fitting to make contact with the Teflon ring and then tighten an additional 1/2 turn. No thread sealant is needed. Insert the bail clamp into the lower bracket. Next, attach the lower bracket and disk to the air spring using the 3/8"x 3/4" hex bolt (see *Figure "A"*). Note: Finger tighten the bolt securing the lower bracket and disk allowing the air spring to move freely. **This will be tightened after alignment in Step 6.**

## STEP 3 - ATTACH LOWER BRACKET TO LEAF SPRING

Place the assembly on the left side on top of the leaf spring stack forward of the axle (see *Figure "A"* and *"B"*). Note the slight difference in the lower bracket position on top of the leaf spring plate between Ford and GM. Attach the lower bracket to the leaf stack using the bail clamp (installed earlier), the bracket strap, and the flange lock nuts as shown in *Figure "A"* and *"B"*. (Tighten to 15-20 ft. lbs.)

## STEP 4- (GM TRUCKS)

CAUTION: The frame rails on some GM trucks have reinforcing ribs used to strengthen to the frame rail. **DO NOT** drill through these ribs. If the holes in the upper bracket align with these ribs, choose another hole which is not on the rib and let the upper bracket rest against the rib. You must use 2 holes on each side of the upper bracket. *GM trucks with the reinforcing ribs will require a flat washer between the upper bracket and the frame to allow the upper bracket to rest squarely against the rib.*

## STEP 4- (FORD TRUCKS)

On FORD vehicles, unbolt the brake line bracket from the left frame rail. Using the existing hardware, attach the brake line bracket onto the brake line relocating bracket provided. This relocating bracket will be attached to the inside of frame using the upper bracket mounting bolts. Relocation is necessary to prevent the original brake line bolt from rubbing the air spring. See *Figures "A"* & *"C"* for mounting.

## **STEP 5 – MARK AND DRILL HOLES IN THE FRAME RAIL**

Visually align the air spring so that it is vertically straight and the upper and lower brackets are parallel. Place the upper bracket so the top of the bracket is parallel with the top of the frame rail. (*Note: The upper bracket should not extend beyond the top of the frame rail.*) see Figure "A" and "B". Check the "X" dimension on both sides of the air spring, these dimensions should be the same (*refer to Figure "B"*). *Before drilling the holes make sure all electrical, brake and fuel lines are cleared from the path of the drill.* In order to prevent any damage to these lines it is recommended that a piece of wood be placed between the frame rail and the existing lines during drilling. With the air spring assembly in place, mark the upper left hole with a center punch. Drill the hole using a 3/8" drill bit.

## **STEP 6 – (ALL ) ATTACHING THE UPPER BRACKET**

Your kit includes 3/8" nut plates as well as 3/8" flange nuts that will be used to attach the upper bracket to the frame. These nut plates allow entry into the frame in the areas where it would be difficult to use a wrench. Once the hole has been drilled, attach the upper bracket using a 3/8" x 1 1/2" hex bolt and a nut plate (finger tight). (On Ford vehicles use the brake line relocating bracket) This will allow you to adjust the location of the upper bracket. Once the positioning of the upper bracket is parallel with the lower bracket and the "X" dimensions are the same, drill the remaining holes in the frame rail using the upper bracket as a template. Use the 3/8" x 1 1/2" hex bolts and nut plate on the front portion of the frame rail. Use the 3/8" x 1 1/2" hex bolts, large flat washers (inside of the frame) and the flanged hex nuts to fasten the upper bracket to the frame rail. Figure "A". Tighten the bracket attaching bolts to 28 – 32 ft. lbs. **Once the upper bracket is secure, align the bottom of the air spring side to side to ensure that it is vertical.** Tighten the bolt securing the lower bracket to the air spring.

## **STEP 7 - INSTALLATION OF THE RIGHT SIDE ASSEMBLY**

Follow steps 1-5, reversing all orientations, for assembly and installation of the passenger's side assembly. Both air helper springs will install just to the front of the axle.

### **Important:**

**In order for the air spring to function properly,  
there must be a minimum of 1/2" of clearance  
around the air spring.**

### **STILL HAVE QUESTIONS?**

#### **Tech line hours**

Monday - Friday 8Am - 6PM (EST) ..... 812-482-2932

