

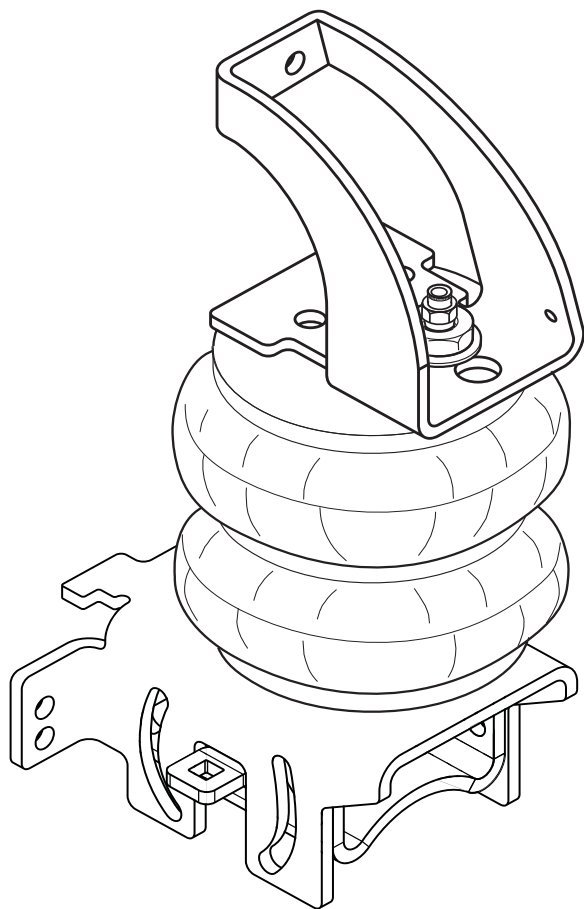

81223011 08-10 F250, F350 2WD, 11-15 F250, F350 2WD Gas

Congratulations - your new TowPro Helper Springs are quality products capable of improving the handling and comfort of your vehicle. As with all products, proper installation is the key to obtaining all of the benefits your kit is capable of delivering. Please take a few minutes to read through the instructions to identify the components and learn where and how they are used. It is a good idea to start by comparing the parts in your kit with the parts list below.



Components

224C AIR SPRING	6401	2
LEFT UPPER BRACKET	5840	1
RIGHT UPPER BRACKET	5846	1
LOWER BRACKET	5842	2
SADDLE BRACKET	5844	2
FUEL LINE BRACKET	5428	1
AXLE STRAP	1163	2
1/2" SPACER	5477	4
1/4" SPACER	5665	4
HEAT SHIELD	1004	1
BAIL CLAMP	3077	2

Hardware

THERMAL SLEEVE	2
TIE-WRAPS	6
3/8"-16 X 5/8" FLAT HEAD BOLT	2
3/8" FLAT WASHER	1
5/16" FLAT WASHER	4
3/8"-16 X 1 1/2" HEX HEAD BOLT	1
3/8"-16 X 1" HEX HEAD BOLT	8
3/8"-16 X 2-1/2" FLAT HEAD BOLT	2
3/8"-16 X 3" CARRIAGE BOLT	4
3/8"-16 FLANGE LOCK NUT	19
3/8" LARGE FLAT WASHER	2
3/4"-16 X 1-3/4" HEX HEAD BOLT	2
3/4"-16 HEX NUT	2
3/4"-16 FRAME NUT	1
3/4" INTERNAL TOOTH LOCKWASHER	2
3/4" LOCK WASHER	1
3/4" FLAT WASHER	1
3/4" THICK FLAT WASHER	1







WARNING!

Do not inflate this assembly when it is unrestricted. The assembly must be restricted by the suspension or other adequate structure. Do not inflate beyond 100 P.S.I. Improper use or over inflation may cause property damage or severe personal injury.

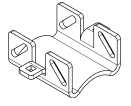
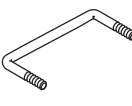
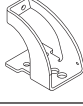
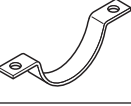

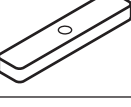
PARTS

Compare the parts below to your kit. Assure you have all pieces, and organize them for an easier installation.















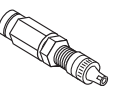



MAIN KIT CONTENTS

PART # 6401		x 2 AIR SPRING	PART # 5844		x 2 SADDLE BRACKET	PART # 3077		x 2 BAIL CLAMP
PART # 5840		x 1 LEFT SIDE UPPER BRACKET	PART # 1163		x 2 AXLE STRAP BRACKET	PART # 1004		x 1 HEAT SHIELD
PART # 5846		x 1 RIGHT SIDE UPPER BRACKET	PART # 5477		x 4 1/2" SPACER	PART # 9415		x 1 AIR LINE TUBE (22 FEET)
PART # 5842		x 2 LOWER BRACKET	PART # 5665		x 4 1/4" SPACER			

A24-760-7560 INFLATION VALVE BRACKET KIT

PART # 9483		x 1 NO-DRILL INFLATION VALVE BRACKET	PART # 9488		x 2 LARGE NYLON TIE
-------------	--	--------------------------------------	-------------	---	---------------------

A21-760-2597 HARDWARE PACK

PT # 3029		x 1 3/8" - 16 x 1 1/2" HEX HEAD BOLT	PT # 3067		x 19 3/8" - 16 FLANGE LOCK NUT	PT # 3296		x 1 3/4" LOCK WASHER
PT # 0071		x 1 3/8" FLAT WASHER	PT # 0532		x 2 3/8" LARGE FLAT WASHER	PT # 3032		x 2 INFLATION VALVE AND VALVE CAP ASSEMBLY
PT # 3033		x 4 5/16" FLAT WASHER	PT # 3350		x 1 3/4" - 16 x 1 3/4" HEX HEAD BOLT	PT # 3046		x 2 AIR FITTING
PT # 3142		x 2 3/8" - 16 x 5/8" FLAT HEAD BOLT	PT # 3295		x 2 3/4" - 16 HEX NUT	PT # 3012		x 4 3/8" - 16 x 3" CARRIAGE BOLT
PT # 3411		x 1 3/4" THICK WASHER	PT # 3412		x 1 3/4" - 16 FRAME NUT	PT # 9036		x 6 RED NYLON TIE
PT # 0070		x 8 3/8" - 16 x 1" HEX HEAD BOLT	PT # 3064		x 2 INTERNAL TOOTH LOCK WASHER	PT # 0899		x 2 THERMAL SLEEVE
PT # 3345		x 2 3/8" - 16 x 2 1/2" FLAT HEAD BOLT	PT # 3113		x 1 3/4" FLAT WASHER			

CONTENTS AND OVERVIEW

PAGE **4** REMOVE JOUNCE BUMPER & INSTALL UPPER BRACKET

PAGE **5** FASTEN AIR SPRING TO UPPER BRACKET

PAGE **6** INSTALL LOWER BRACKET ASSEMBLY

PAGE **7** SECURE LOWER BRACKET

PAGE **8** INSTALL RIGHT SIDE UPPER BRACKET

PAGE **9** HEAT SHIELD & PASSENGER SIDE

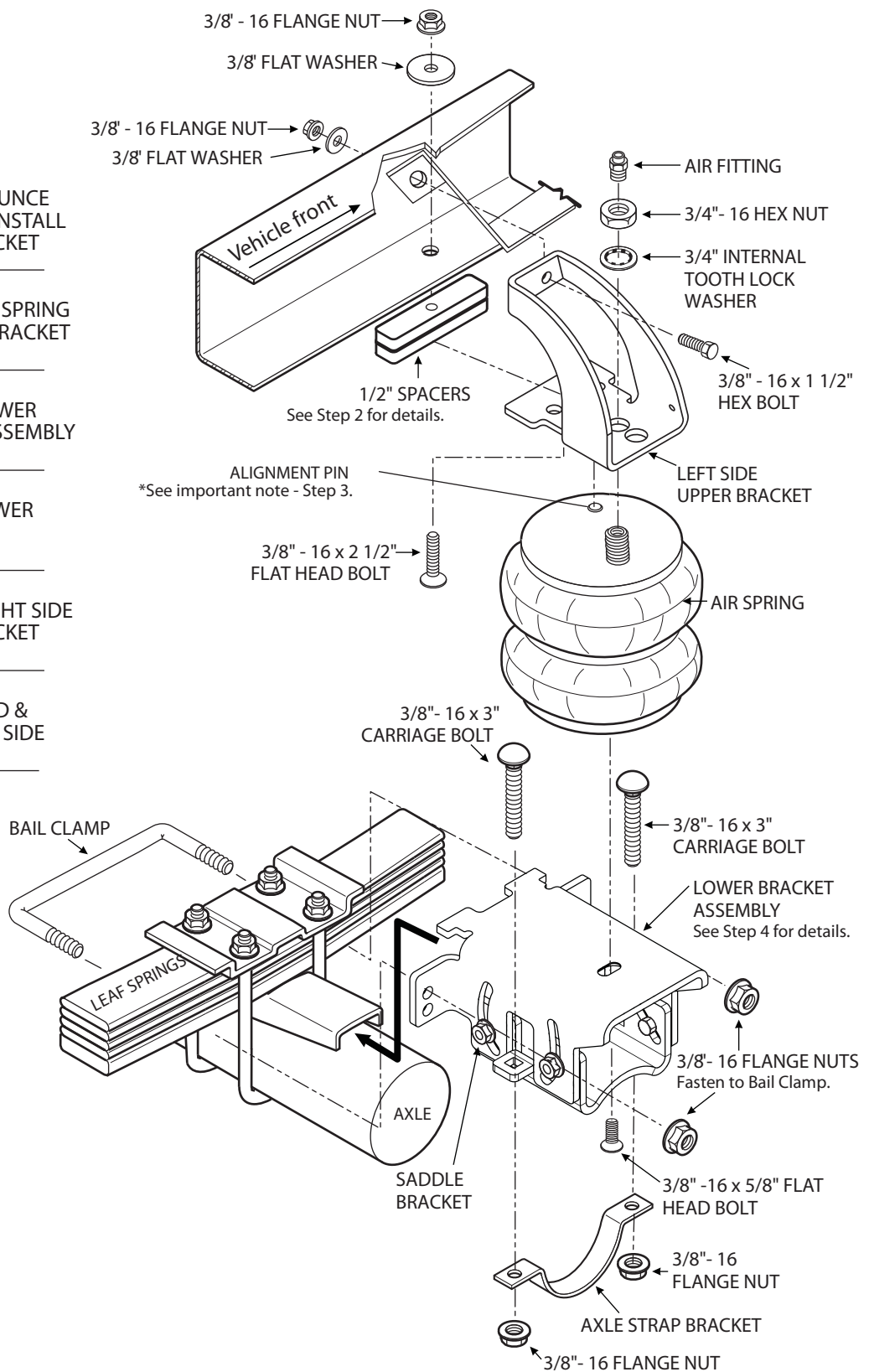

REMOVE EXISTING JOUNCE BUMPER & UREA TANK BOLT AND CLIP

1



THIS STEP IS FOR DIESEL TRUCKS ONLY.

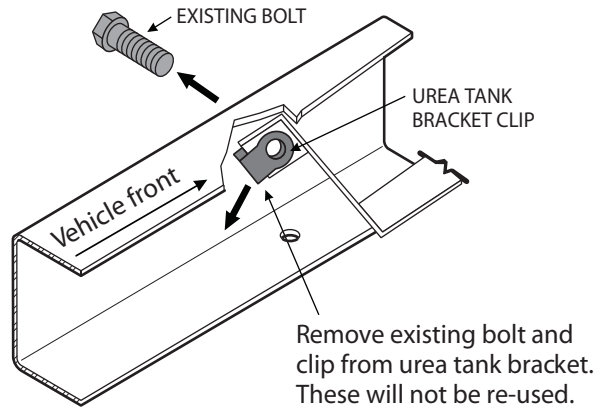
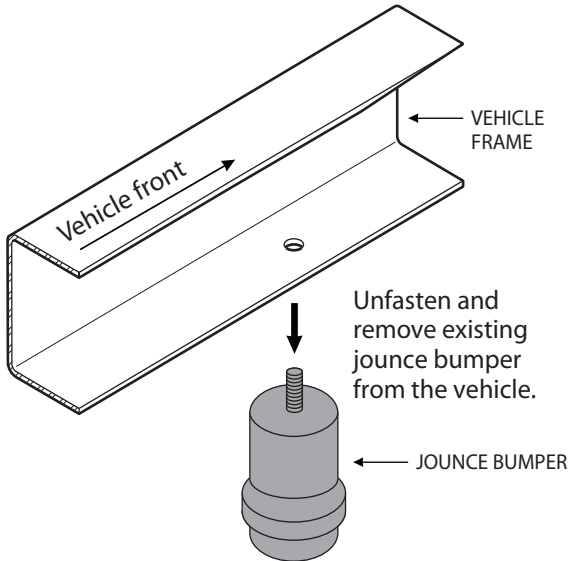

INSTALL LEFT SIDE UPPER BRACKET

2

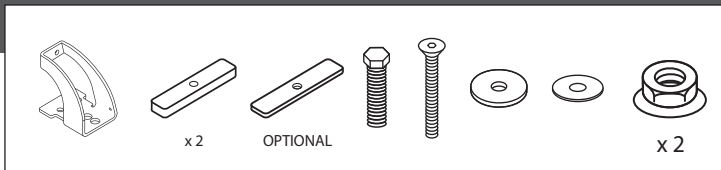

ASSURE NO WIRING OR LINES ARE PINCHED BETWEEN THE BRACKET AND FRAME.

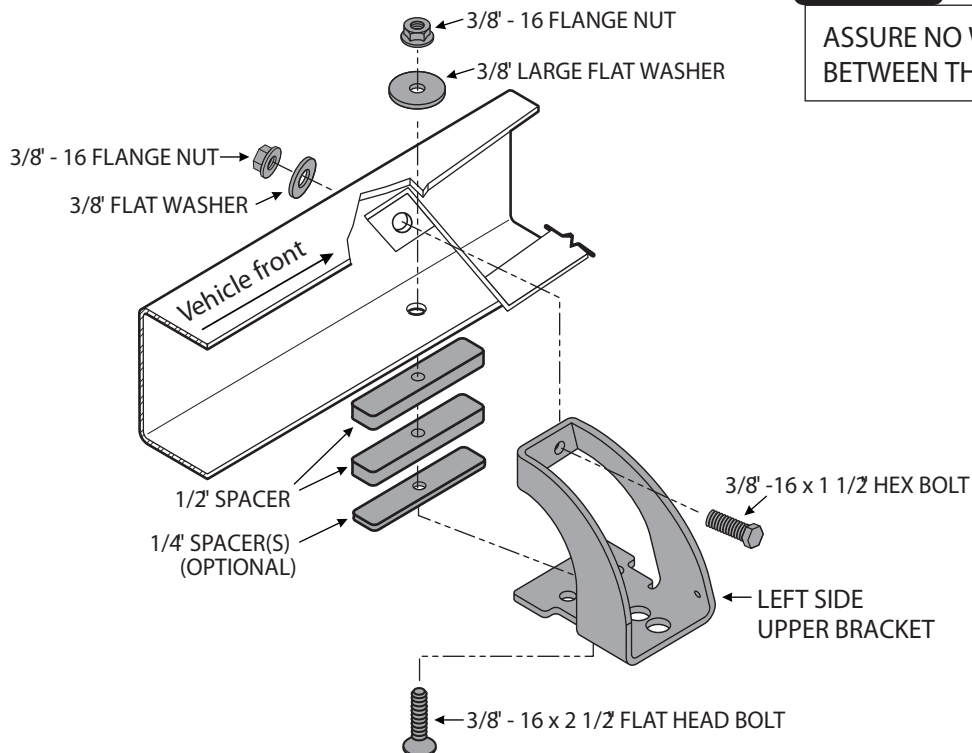

3

FASTEN AIR SPRING TO UPPER BRACKET

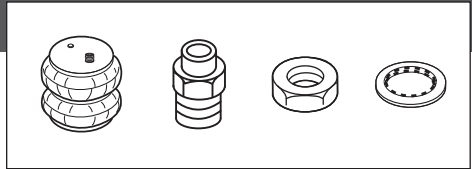

INSTALLING THE RIGHT SIDE? REMEMBER TO INSTALL THE HEAT SHIELD IN STEP 7 FIRST!

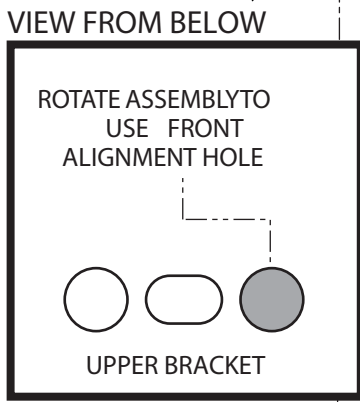
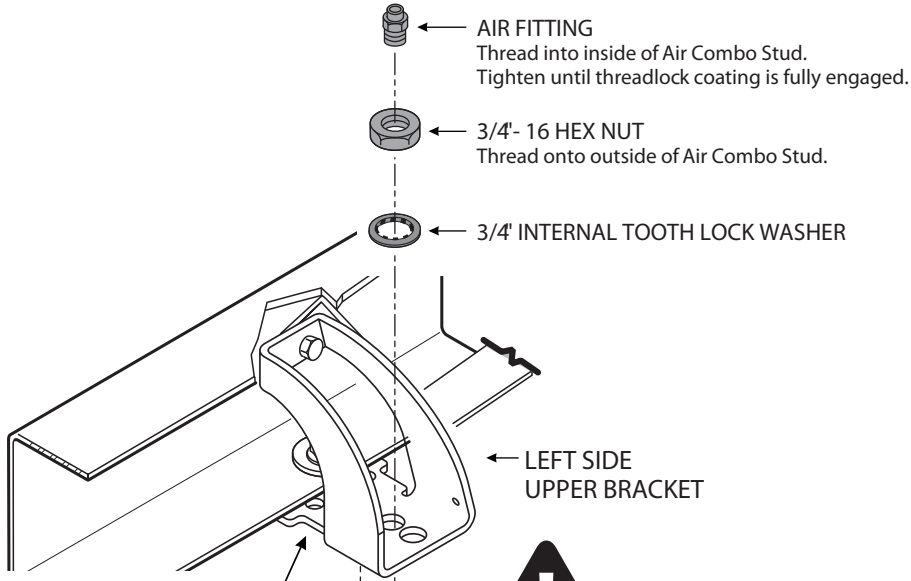

ALIGNMENT PIN ON AIR SPRINGS MUST BE INSTALLED TO FULLY SEAT INTO THE FRONT ALIGNMENT HOLE IN THE UPPER BRACKET. FAILURE TO DO SO WILL CAUSE IT TO BE PUSHED INTO THE BEAD PLATE, CREATING AN AIR LEAK, AND RESULTING IN AN AIR SPRING FAILURE THAT IS NOT WARRANTABLE. THE ALIGNMENT PIN CANNOT HOLD 2,500 LBS! IT IS USED FOR ALIGNMENT ONLY!

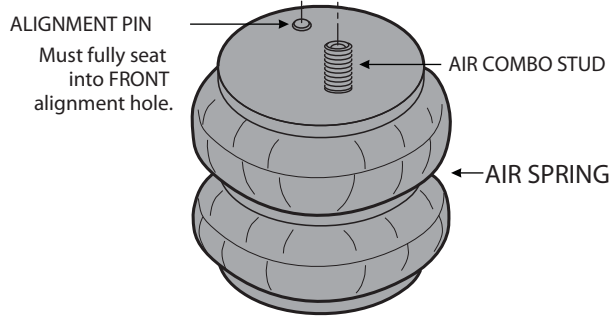

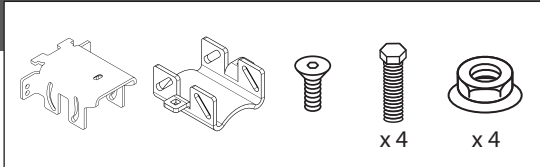

1 Follow steps below to dry fit assembly. Make alignment marks as shown.

2 Place bottom of Lower Bracket on the axle of the vehicle.

3 Place the Upper Bracket above the Lower Bracket as shown. Assure both are tight against the leaf spring stack.

4 Match the alignment marks and secure the Air Spring to the Upper Bracket, as shown.

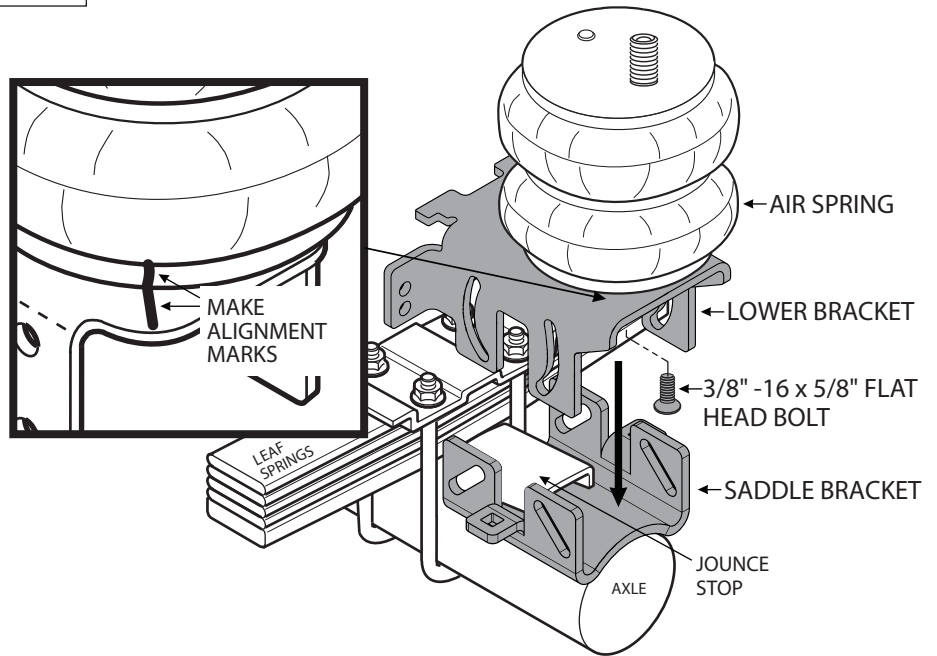

5 Position the Lower Bracket as low as possible, while still clearing the jounce stop on the vehicle.

6 Make sure the Lower Bracket is parallel to the ground.

7 Use supplied fasteners in the bracket bolting slots.

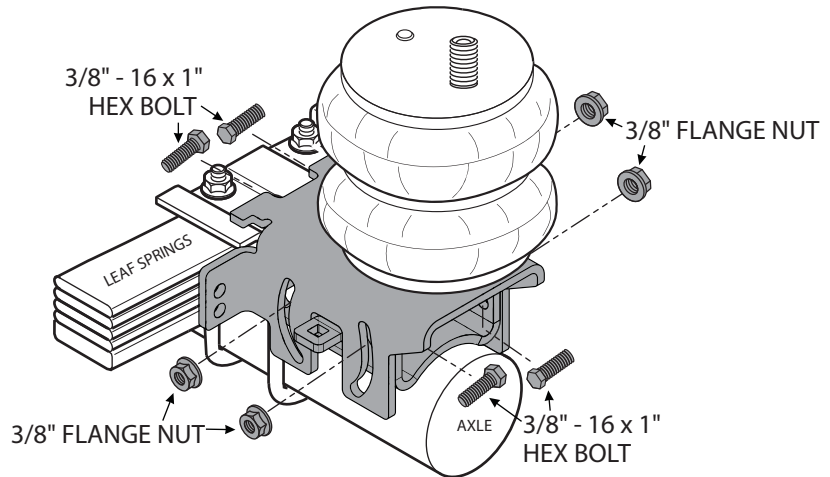

! IMPORTANT: INSTALL ON THE LOWEST SETTING POSSIBLE FOR YOUR VEHICLE
 FAILURE TO DO SO CAN RESULT IN DAMAGED BRACKETS AND CAN VOID YOUR WARRANTY

4-WHEEL DRIVE INCORRECT

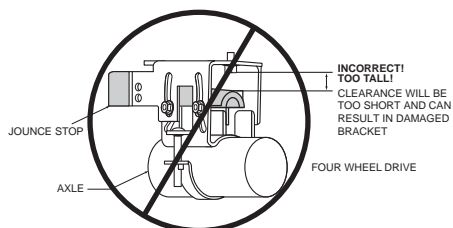

4-WHEEL DRIVE CORRECT

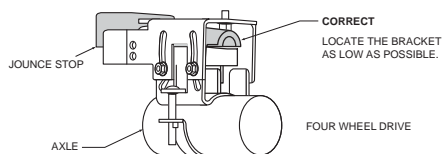

2-WHEEL DRIVE CORRECT

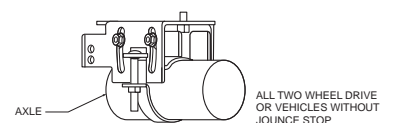

5

SECURE LOWER BRACKET



USE YOUR HAND TO CHECK FOR THE PROPER CLEARANCE AROUND THE AIR SPRING. IF YOUR HAND DOES NOT FIT BETWEEN THE AIR SPRING AND OTHER COMPONENTS, IT WILL RUB!

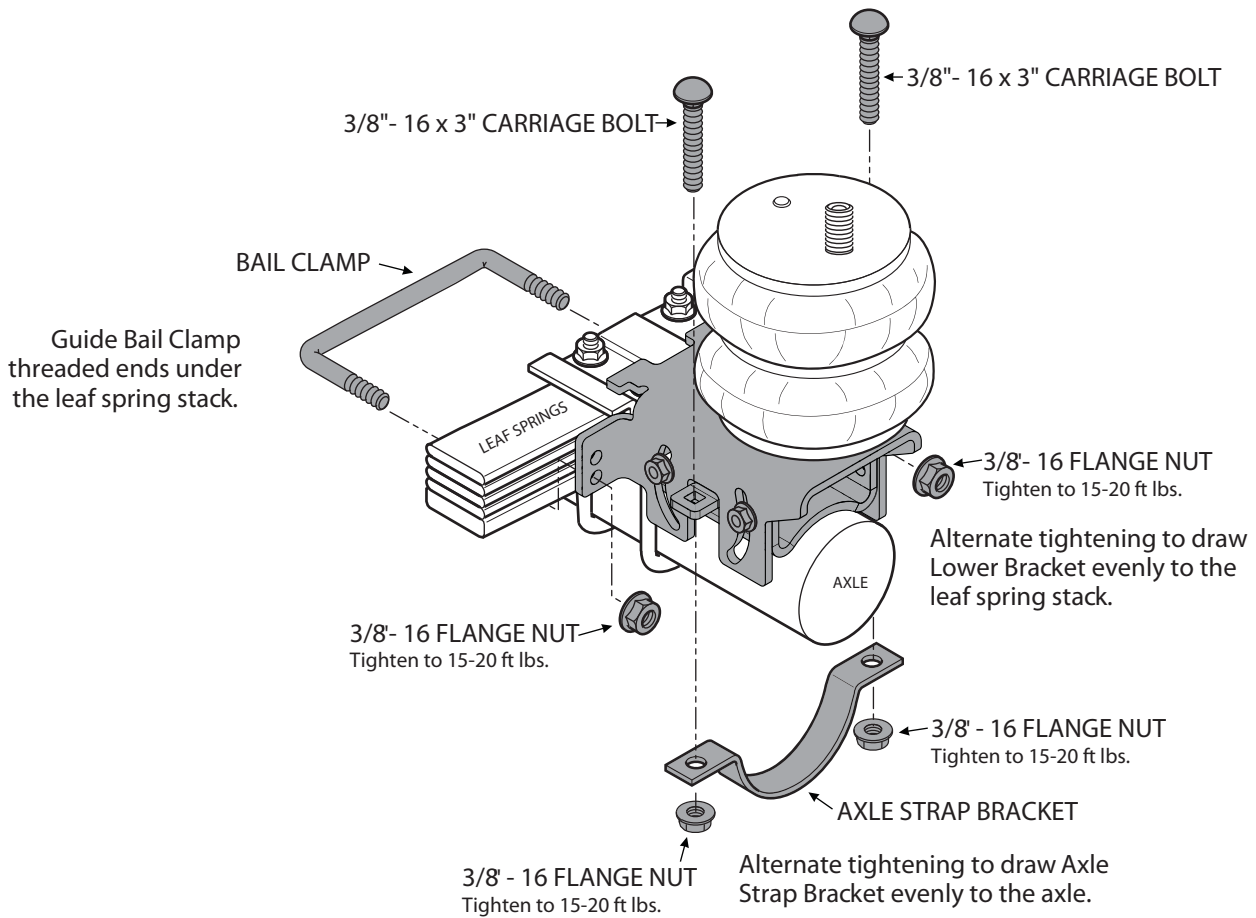
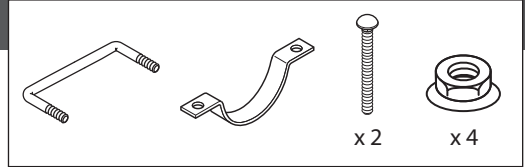

AWESOME! You're done with the left side. Move on to Step 6 to begin the right side installation.

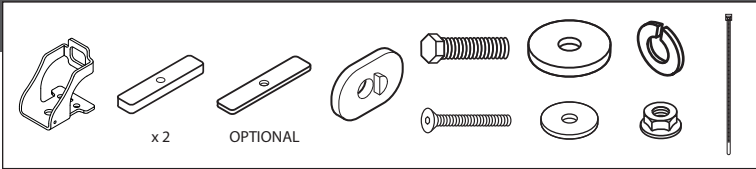

1 Follow the steps below to install the right side Upper Bracket.

2 Use supplied Nylon Tie to secure parking brake line to Upper Bracket as shown.

3 Once completed, see Step 7 for Heat Shield Installation.

4 Once Step 7 is complete for the right side, continue to Steps 3-5.



ASSURE NO WIRING OR LINES ARE PINCHED BETWEEN THE BRACKET AND FRAME.

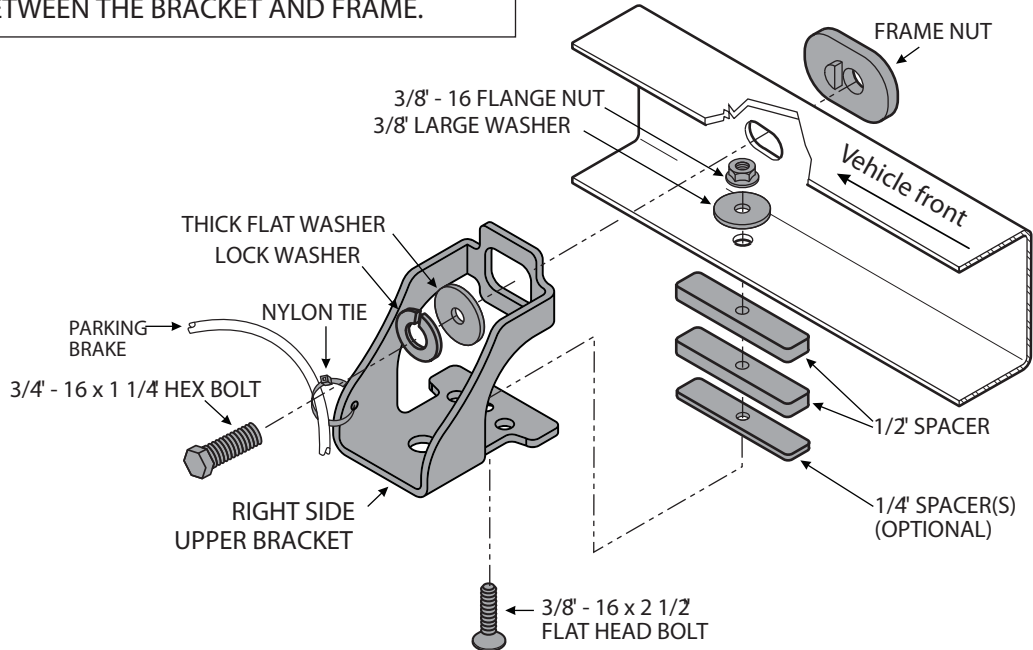

7

INSTALL RIGHT SIDE WITH HEAT SHIELD

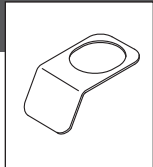

RIGHT SIDE INSTALLATION MUST INCLUDE HEAT SHIELD!

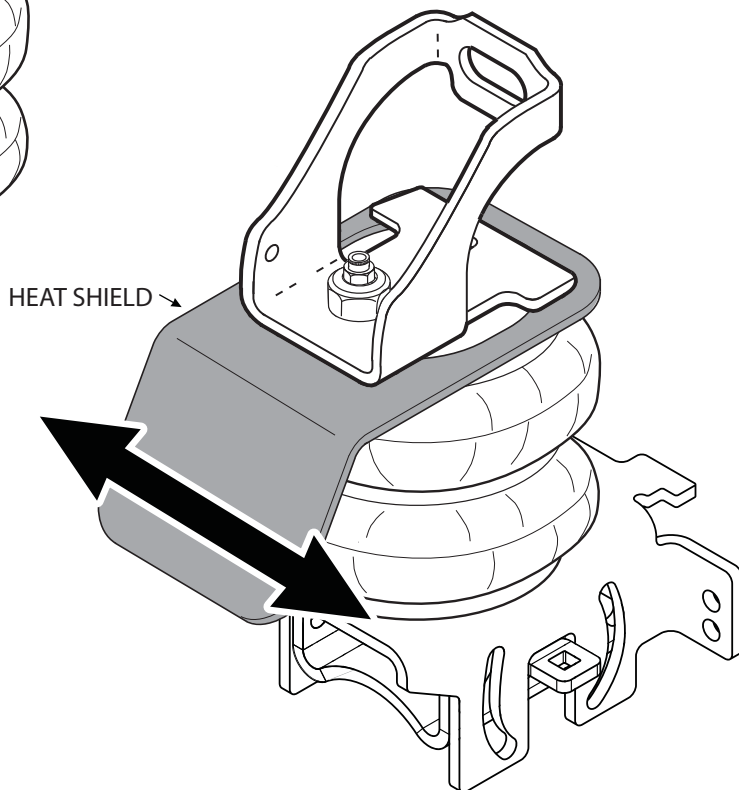
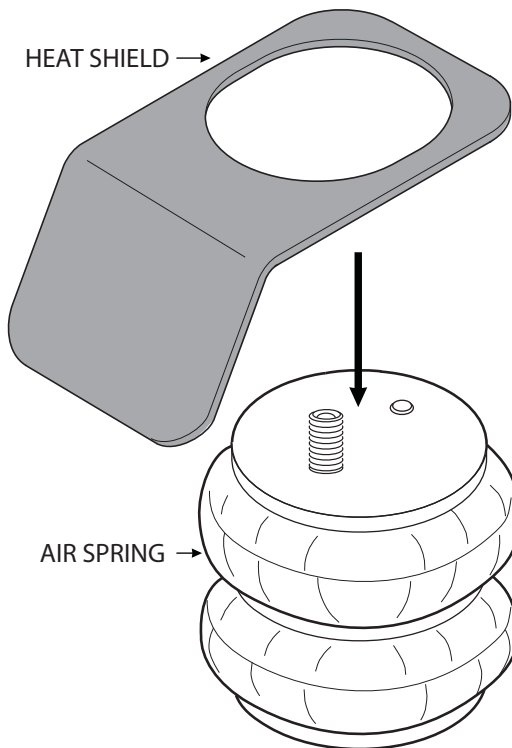

Position Heat Shield to
closest point of exhaust.
DO NOT PLACE
DIRECTLY ABOVE AXLE.

STILL HAVE QUESTIONS?

Tech line hours

Monday - Friday 8Am - 6PM (EST) 812-482-2932

