

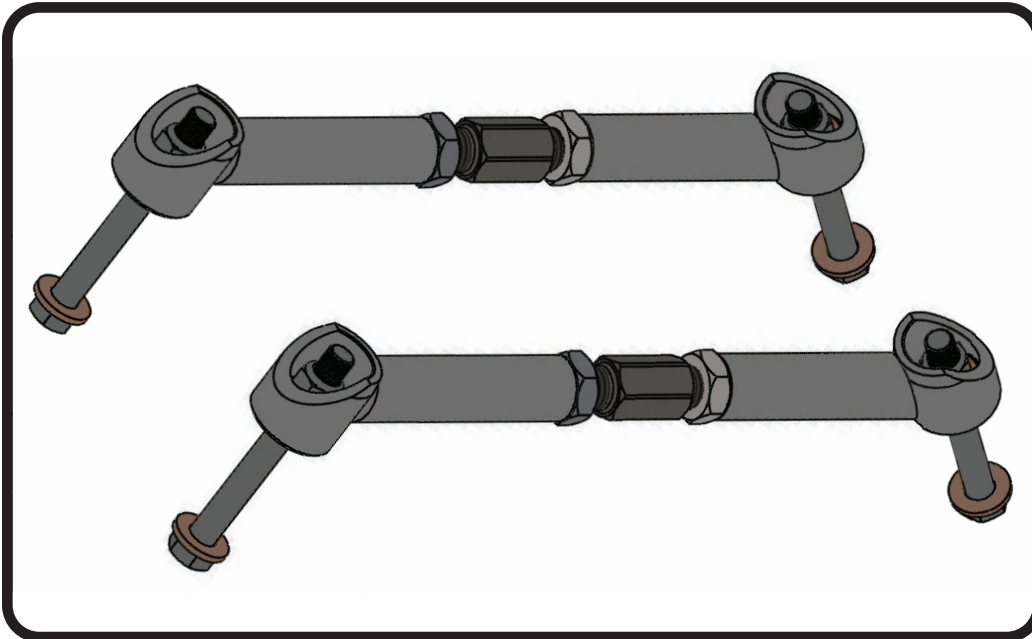

Part # 11237299 - 1964-1967 A-Body Rear Control Arm Brace

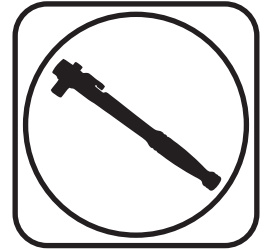

Recommended Tools



1964-1967 GM "A" Body Rear Control Arm Brace Installation Instructions

Table of contents

- Page 2..... Included Components & Hardware
- Page 3-4..... Installation





Included ComponentsIn the box

Item #	Part #	Description	QTY
1	90003353	Upper Frame Brace Half - Right Hand Thread	2
2	90003354	Lower Frame Brace Half - Left Hand Thread	2
3	70015662	Frame Brace Adjuster - 3/4"-16 RH & LH Thread	2

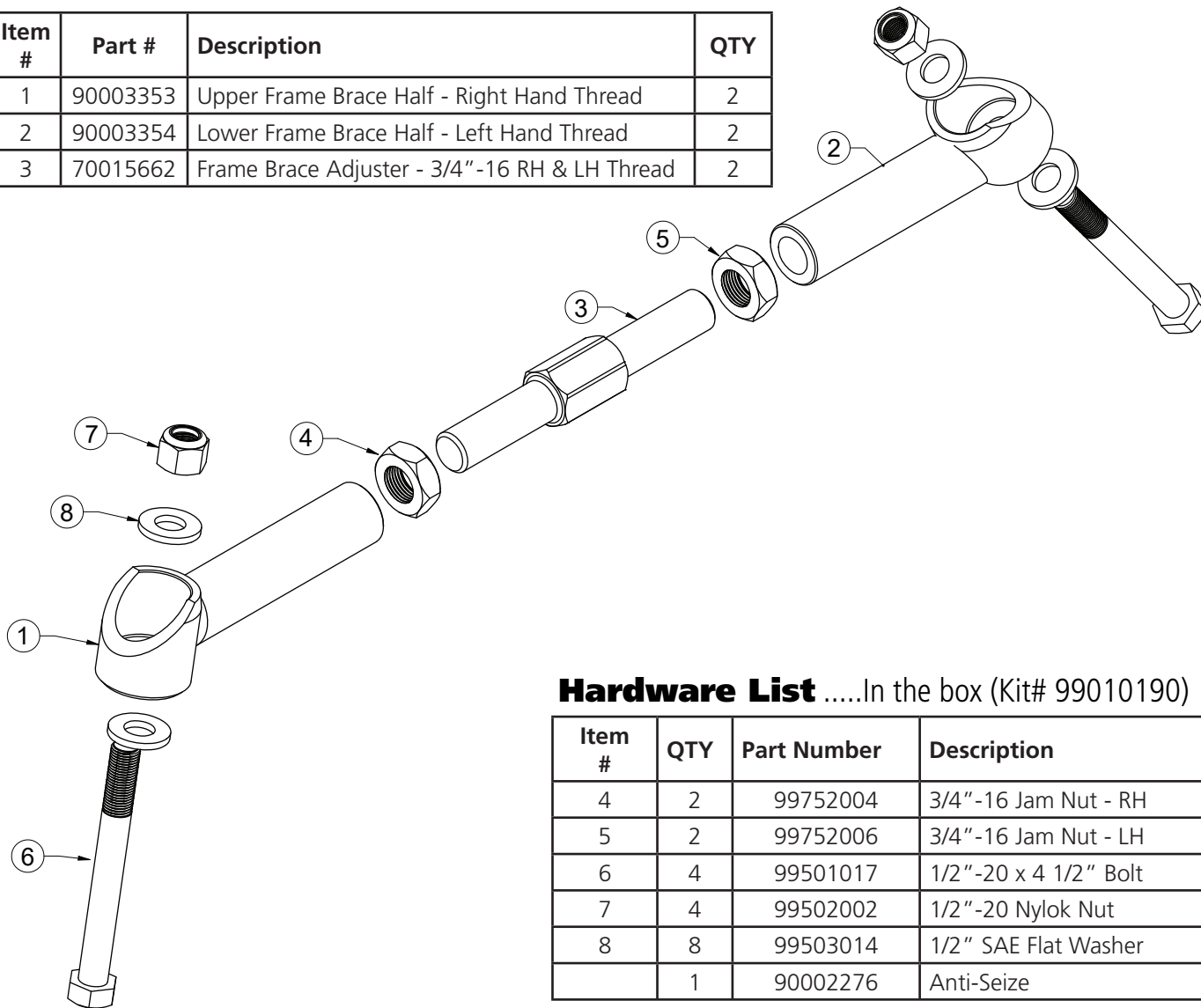

Hardware ListIn the box (Kit# 99010190)

Item #	QTY	Part Number	Description
4	2	99752004	3/4"-16 Jam Nut - RH
5	2	99752006	3/4"-16 Jam Nut - LH
6	4	99501017	1/2"-20 x 4 1/2" Bolt
7	4	99502002	1/2"-20 Nylok Nut
8	8	99503014	1/2" SAE Flat Washer
	1	90002276	Anti-Seize

Notes and Tips

This brace kit links the upper control arm with the lower control arm to help reduce rear frame flex.

1. If your car came equipped with OEM frame braces, they will be removed during the installation of these braces.
2. If you are replacing the rear control arms, install the braces in conjunction with the control arms.
3. We found the best way to install the braces on a finished car is to remove and replace one bolt at a time.
4. The brace has a top and bottom. The top of the brace has less angle than the bottom.
5. Install the top of the brace first. It makes it easier to adjust the brace to align the lower bolt.



Frame Brace Installation

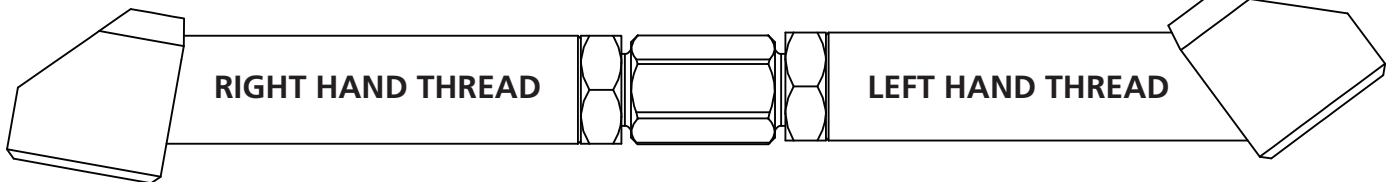

TOP

BOTTOM

Assemble the frame braces. The frame braces are LEFT hand and RIGHT hand thread. The top half of the brace is Right hand thread, the bottom half is Left hand thread. Each half has a different angle for the mounting bolt. The bottom half has more angle at the mounting bolt.

The adjuster has left hand thread on one side, right hand thread on the other. To assemble, thread a jam nut on each side of the adjuster. APPLY ANTI-SEIZE TO THE THREADS OF THE ADJUSTER. Thread the nuts all the onto the adjuster. Thread the correct frame brace half on each side of the adjuster. Thread them all the one on to the adjuster. This will keep the thread engagement the same on both halves of the brace.



6. Remove one of the upper bar bolts. Install a 1/2" SAE flat washer on a 1/2"-20 x 4 1/2" bolt. Align the top of the frame brace with the top upper bar hole. With them aligned, insert the bolt/washer in the aligned holes. Install a 1/2" SAE flat washer and 1/2"-20 nylok nut on the threads of the bolt. Snug down the hardware, but leave it loose enough to move the brace for alignment of the lower bolt.



7. Remove the OEM bolt out of the front lower control arm. Position the bottom mount of the brace close to the lower control arm mounting hole. While holding the bottom of the brace in position, turn the adjuster until the bottom brace hole is aligned with the lower control arm hole.



Frame Brace Installation



8. Install a 1/2" SAE flat washer on a 1/2"-20 x 4 1/2" bolt. Insert the bolt/washer through the OEM brace, lower control arm, and frame brace.



9. Install a 1/2" SAE flat washer and 1/2"-20 nylok nut on the threads of the bolt.

Torque the upper and lower bolt to 120 ft-lbs.



10. Tighten the jam nuts against the brace bars.

Repeat the previous steps on the 2nd side.